

B	H	A	Model
250mm	200mm	25mm	
400mm	200mm	25mm	
400mm	400mm	50mm	
400mm	600mm	50mm	
600mm	400mm	50mm	
540mm	75mm	22,5mm	19" 1 Scharnier
540mm	120mm	27,5mm	19"
540mm	160mm	27,5mm	19"
540mm	300mm	27,5mm	19"
540mm	440mm	27,5mm	19"
600mm	600mm	50mm	
600mm	800mm	50mm	2 Schlösser
800mm	800mm	50mm	2 Schlösser

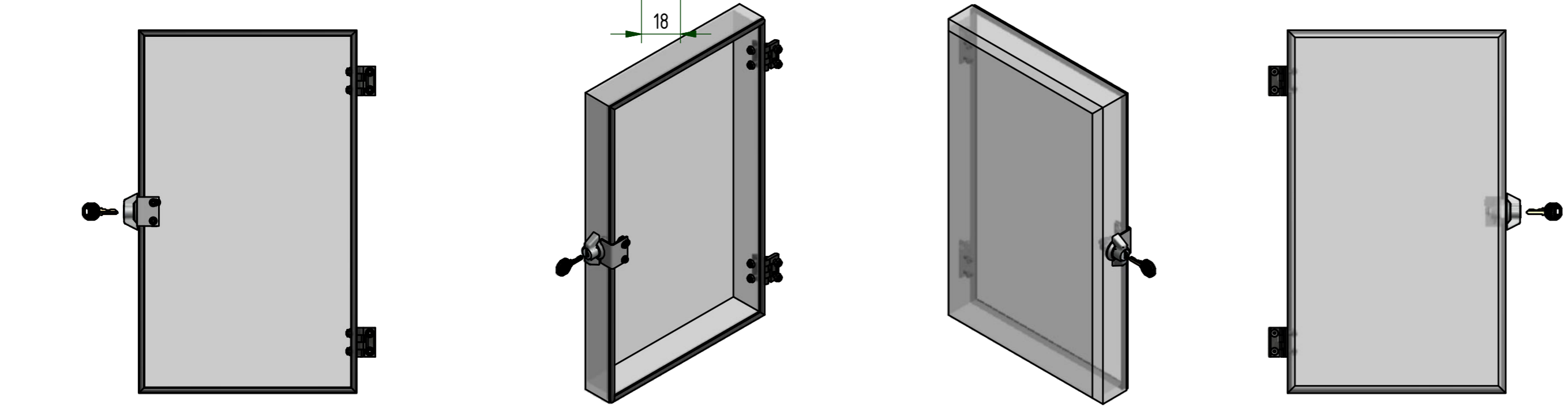

Zylinder-Vorreiber (Standard) inkl. 2 Schlüssel
Art.-Nr. : 105606

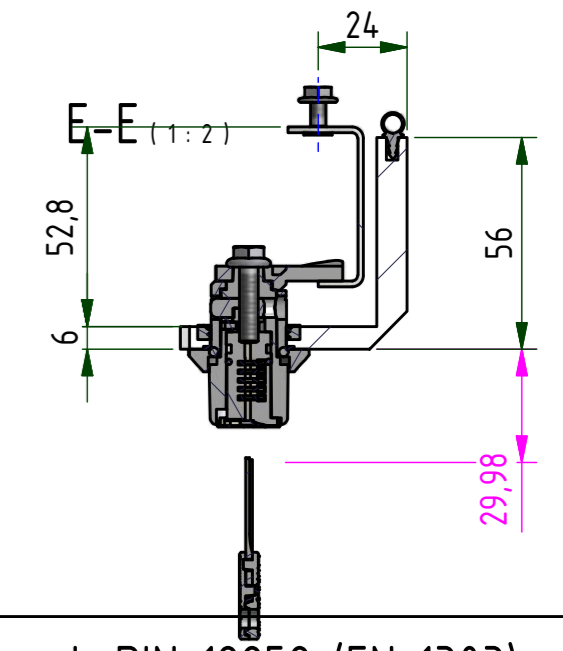
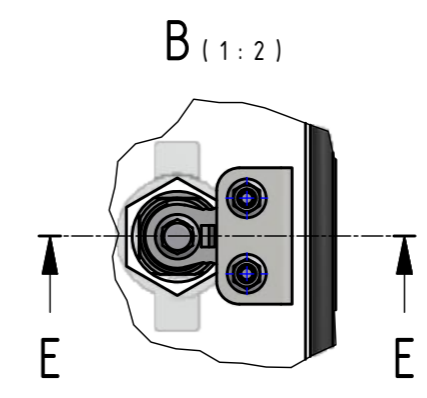

Für kundeneigene Profil-Halbzylinder nach DIN 18252 (EN 1303)
Art.-Nr. : 103586

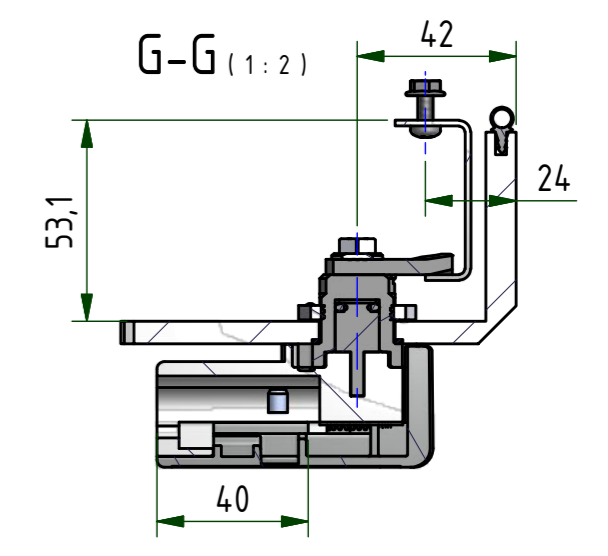
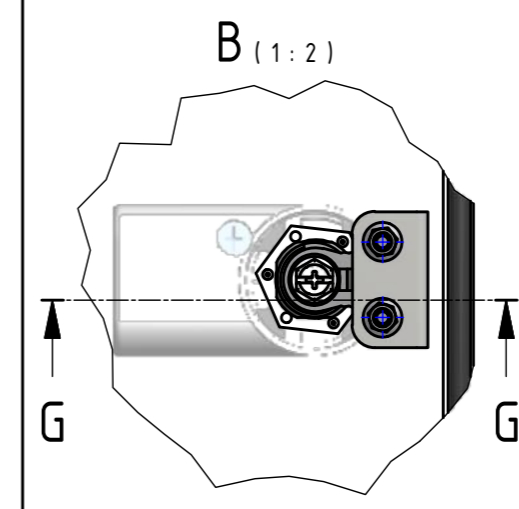

Magnetverschluß
Art.-Nr. : 102714

B (1:3)

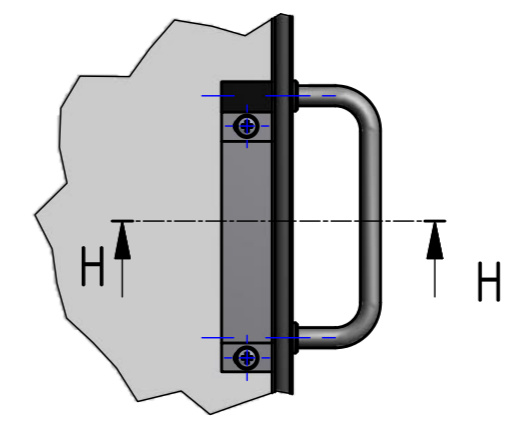

H-H (1:3)

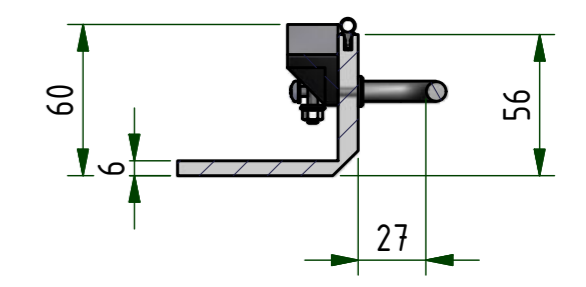

Technische Änderungen, die weder die Qualität noch die Funktion der gelieferten Teile beeinflussen, werden von uns ohne Vorankündigung vorgenommen.

		CAD		Maßstab		Freimaßtoleranz	
		Änderungen nur mit CAD zulässig		%		DIN ISO 2768 mittel	
				Werkstoff		Gewicht	
a 1 Innenmaß bestimmt		29.05.2026 Bastian		Datum Name		kg	
Index		Anzahl		Proj.-Nr.		Ausg.Datum	
Benennung		Name		Norm		Datum	
SRA Übersicht Aufsatzfenster aus Acrylglas		110424		Blatt 1 von 1		Ursprungszeichnung: 12-02	
Format		A2		Index		b	

